



2.0SMPC SERIES

High power density 2KW TVS

Reverse Voltage - 11 to 140 Volts

Peak Pulse Power- 2000 Watts

A3PS-C

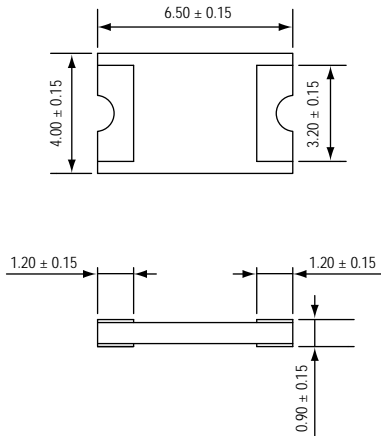
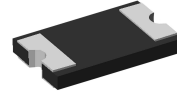

*Dimensions in millimeters

CoolTc™

FEATURES

- * Halogen-free type
- * Compliance to RoHS product
- * World's First 2KW TVS in TO-277A equivalent package
- * Pad layout compatible with SMC for easy drop-in replacement
- * Glass passivated chip
- * 2000 W peak pulse power capability with a 10/1000 μs waveform, repetitive rate (duty cycle) : 0.01%
- * Low leakage
- * Lowest profile 1mm
- * Excellent clamping capability
- * Very fast response time

MECHANICAL DATA

Case : A3PS-C

Terminals : Solder plated, solderable per MIL-STD-750, Method 2026

MAXIMUM RATINGS AND ELECTRICAL CHARACTERISTICS

*Ratings at 25 °C ambient temperature unless otherwise specified.
single phase, half wave, 60Hz resistive or inductive load.
for capacitive load, derate current by 20%*

RATING	SYMBOL	VALUE	UNITS
Peak power dissipation with a 10/1000 μs waveform	PPPM	2000	Watts
Peak pulse current with a 10/1000 μs waveform	IPPM	See next table	Amps
Power dissipation on infinite heatsink at T _L = 75	P _D	6.5	Watts
Operating junction and storage temperature range	T _J , T _{STG}	-55 to +150	

PART NUMBER	Marking Code	Working Peak Reverse Voltage V_{RWM} (V)	Breakdown Voltage V_{BR} @ I_T			Maximum Clamping Voltage V_C (V) @ I_{PP}	Maximum Reverse Surge Current I_{PP} (A) @ 10 / 1000 μ s sinewave	Maximum Reverse Leakage I_R (μ A) @ V_{RWM}
			Min. (V)	Max. (V)	I_T (mA)			
BI-POLAR								
2.0SMPC11CAH	2.0C 11CA•	11	12.2	13.5	1	18.2	109.89	5
2.0SMPC12CAH	2.0C 12CA•	12	13.3	14.7	1	19.9	100.50	5
2.0SMPC13CAH	2.0C 13CA•	13	14.4	15.9	1	21.5	93.02	1
2.0SMPC14CAH	2.0C 14CA•	14	15.6	17.2	1	23.2	86.21	1
2.0SMPC15CAH	2.0C 15CA•	15	16.7	18.5	1	24.4	81.97	1
2.0SMPC16CAH	2.0C 16CA•	16	17.8	19.7	1	26.0	76.92	1
2.0SMPC17CAH	2.0C 17CA•	17	18.9	20.9	1	27.6	72.46	1
2.0SMPC18CAH	2.0C 18CA•	18	20.0	22.1	1	29.2	68.49	1
2.0SMPC20CAH	2.0C 20CA•	20	22.2	24.5	1	32.4	61.73	1
2.0SMPC22CAH	2.0C 22CA•	22	24.4	26.9	1	35.5	56.34	1
2.0SMPC24CAH	2.0C 24CA•	24	26.7	29.5	1	38.9	51.41	1
2.0SMPC26CAH	2.0C 26CA•	26	28.9	31.9	1	42.1	47.51	1
2.0SMPC28CAH	2.0C 28CA•	28	31.1	34.4	1	45.4	44.05	1
2.0SMPC30CAH	2.0C 30CA•	30	33.3	36.8	1	48.4	41.32	1
2.0SMPC33CAH	2.0C 33CA•	33	36.7	40.6	1	53.3	37.52	1
2.0SMPC36CAH	2.0C 36CA•	36	40.0	44.2	1	58.1	34.42	1
2.0SMPC40CAH	2.0C 40CA•	40	44.4	49.1	1	64.5	31.01	1
2.0SMPC43CAH	2.0C 43CA•	43	47.8	52.8	1	69.4	28.82	1
2.0SMPC45CAH	2.0C 45CA•	45	50.0	55.3	1	72.7	27.51	1
2.0SMPC48CAH	2.0C 48CA•	48	53.3	58.9	1	77.4	25.84	1
2.0SMPC51CAH	2.0C 51CA•	51	56.7	62.7	1	82.4	24.27	1
2.0SMPC54CAH	2.0C 54CA•	54	60.0	66.3	1	87.1	22.96	1
2.0SMPC58CAH	2.0C 58CA•	58	64.4	71.2	1	93.6	21.37	1
2.0SMPC60CAH	2.0C 60CA•	60	66.7	73.7	1	96.8	20.66	1
2.0SMPC64CAH	2.0C 64CA•	64	71.1	78.6	1	103	19.42	1
2.0SMPC70CAH	2.0C 70CA•	70	77.8	86.0	1	113	17.70	1
2.0SMPC75CAH	2.0C 75CA•	75	83.3	92.1	1	121	16.53	1
2.0SMPC78CAH	2.0C 78CA•	78	86.7	95.8	1	126	15.87	1
2.0SMPC85CAH	2.0C 85CA•	85	94.4	104	1	137	14.60	1
2.0SMPC90CAH	2.0C 90CA•	90	100	111	1	146	13.70	1
2.0SMPC100CAH	2.0C 100CA•	100	111	123	1	162	12.35	1
2.0SMPC110CAH	2.0C 110CA•	110	122	135	1	177	11.30	1
2.0SMPC120CAH	2.0C 120CA•	120	133	147	1	193	10.36	1
2.0SMPC130CAH	2.0C 130CA•	130	144	159	1	209	9.57	1
2.0SMPC140CAH	2.0C 140CA•	140	155	171	1	227	8.81	1

RATINGS AND CHARACTERISTIC CURVES

FIG. 1- PULSE DERATING CURVE

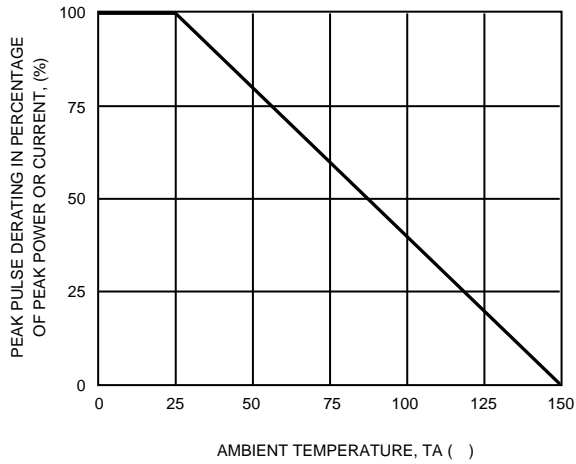

FIG. 2- STEADY STATE POWER DERATING CURVE

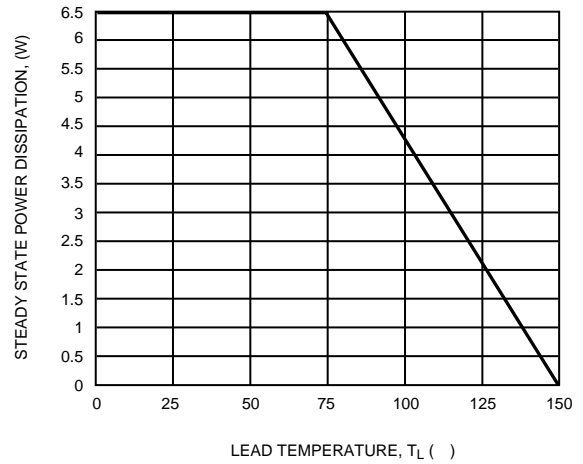

FIG. 3 - PEAK PULSE POWER RATING CURVE

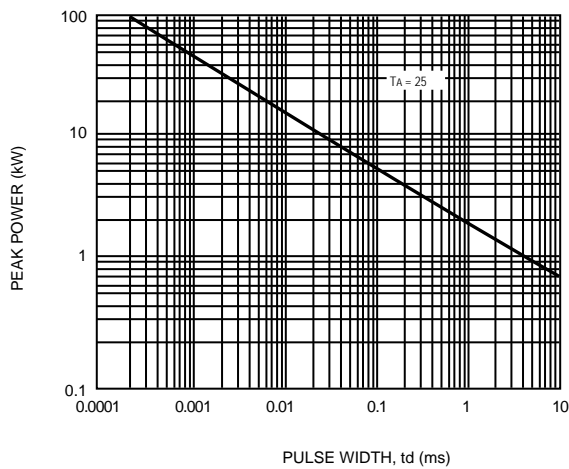

FIG. 4 - PULSE WAVEFORM

